

NOTES:

1. CLEAN SURAFCE WITH ISOPROPYL ALCOHOL & LET DRY BEFORE APPLICATION OF KEYPAD.

REVISIONS				
REV.	DATE	DESCRIPTION	ECO	BY
A	03-07-07	PRODUCTION RELEASE	11558	VC
B	01-04-11	REPLACE P/N: 050-2026 WITH P/N: 050-2202	13469	SJK

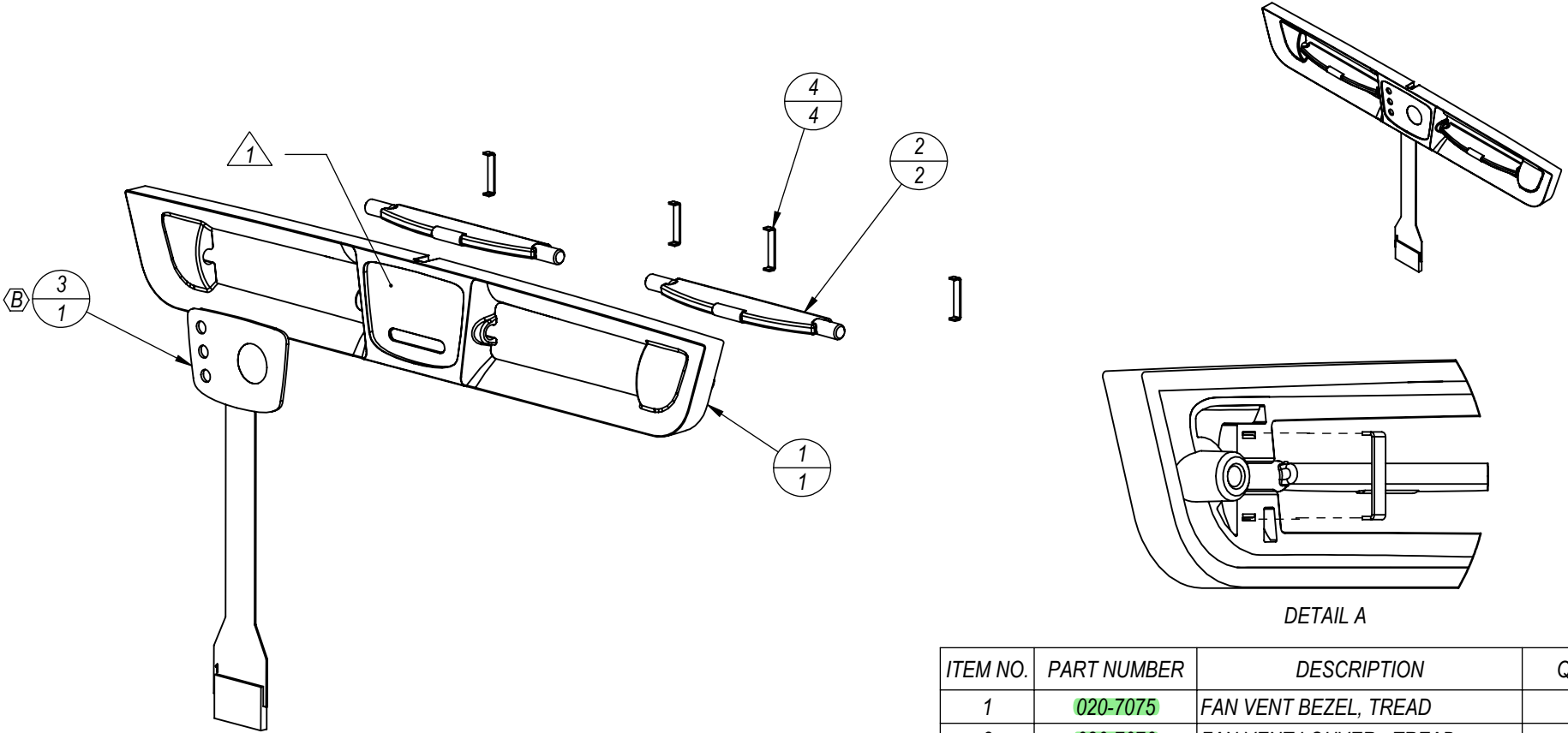

ITEM NO.	PART NUMBER	DESCRIPTION	QTY.
1	020-7075	FAN VENT BEZEL, TREAD	1
2	020-7076	FAN VENT LOUVER - TREAD	2
(B) 3	050-2202	KEYPAD, FAN CONTROL, G2	1
4	140-3394	CLIP, RETAINER, AIR VENT	4

DOCUMENT STATUS:

MATERIAL SEE BOM	TOLERANCES UNLESS OTHERWISE SPECIFIED		UNISEN, INC. DBA 14410 Myford Road Irvine CA 92606
	X.XXX = ± .010" (0.25MM)	ANGLES = ± 2°	
FINISH N/A	X.XX = ± .030" (0.76MM)	FRACTIONS = ± 1/32	STARTRAC PART NO 715-3650
	X.X = ± .050" (1.27MM)		REV B
VENDOR: N/A	INITIAL	DATE	TITLE ASSY, AIR VENT, TREAD, TV/R
			SCALE: 1:2 SHEET 1 OF 1 SHEET SIZE: A
P/N: N/A	U.O.M.	INCH	

NOTICE OF PROPRIETARY INFORMATION
 THIS DOCUMENT SHALL NOT BE REPRODUCED NOR SHALL THE INFORMATION CONTAINED HEREIN BE USED BY OR DISCLOSED TO OTHER EXCEPT AS EXPRESSLY AUTHORIZED BY UNISEN